



Fiber Composite Plates for Strengthening Bridge Beams

Mohammad R. Ehsani & Hamid Saadatmanesh

Department of Civil Engineering and Engineering Mechanics, The University of Arizona, Tucson, Arizona 85721, USA

ABSTRACT

Although the use of Glass Fiber Reinforced Plastics (GFRP) has increased significantly in recent years, its application in civil engineering has been limited at best. The high strength of GFRP and its resistance to corrosion makes it a suitable candidate in many applications where steel has been predominantly used in the past. In this study, five reinforced concrete beams were strengthened by epoxy-bonding GFRP plates along the tension flange of the beams. The load versus deflection curves to failure and the behavior of each specimen under static loading is presented. It is shown that the method presents great potential for solving some of the global problems facing the aging infrastructure.

NOTATION

a	Height of the equivalent stress block
A_p	Cross-sectional area of plate
A_s	Area of tension reinforcement
A_v	Area of shear reinforcement
b	Width of beam
b_p	Width of plate
c	Distance from extreme compression fiber to neutral axis
C_c	Concrete compressive force
d	Distance from extreme compression fiber to centroid of tension reinforcement
e	Distance from position of the applied load to the mid-span of beam
f_f	Tensile stress in plate
f_y	Steel yield strength
f'_c	Compressive strength of concrete
l	Beam span length

M_x	Bending moment at section x
s	Spacing of shear reinforcement in direction parallel to longitudinal reinforcement
t_p	Thickness of plate
T_p	Tensile force in plate
T_s	Tensile force in steel reinforcement
V_x	Shear force at section x

1 INTRODUCTION

Reinforced concrete is the most widely used construction material. In many buildings and bridges, concrete is used in the construction of foundations, columns, girders or beams and slabs. A major problem with reinforced concrete, however, is the corrosion of the reinforcement. In bridges for example, deicing chemicals which are sprayed on the roadway, penetrate through microcracks present in concrete and cause corrosion of the reinforcement. Similar problems are encountered in other structures subjected to adverse environmental conditions such as chemical plants, water and waste water treatment facilities, ports, sea walls, breakwaters, sewer pipelines and the like.

Because the present article deals with the strength of reinforced concrete members subjected to bending, a brief review of the mechanics of reinforced concrete is necessary. More detailed treatment of the subject is provided in many textbooks.^{1,2} Figure 1(a) shows a simply supported reinforced concrete beam with a span length l and subjected to an arbitrary loading. The cross section of the beam is shown in Fig. 1(b). The tension steel reinforcement, A_s , is placed near the bottom of the cross section and spans the entire length of the beam. The shear reinforcement, A_v , is placed at a spacing of s along the span.

The free body diagram of a section of the beam at a distance x from the left support and the strain variation along the height of the beam are shown in Figs 1(c) and 1(d), respectively. To ensure ductile failure, the area of the tension steel is selected such that it will yield before the concrete crushes in compression. Thus, at failure, the tension force provided by the reinforcing steel, T_s , is equal to:

$$T_s = A_s \times f_y \quad (1)$$

where f_y is the yield strength of the steel. The tensile strength of concrete is approximately one-tenth of its compressive strength and is commonly neglected in strength calculations. The internal compressive force, C_c , is

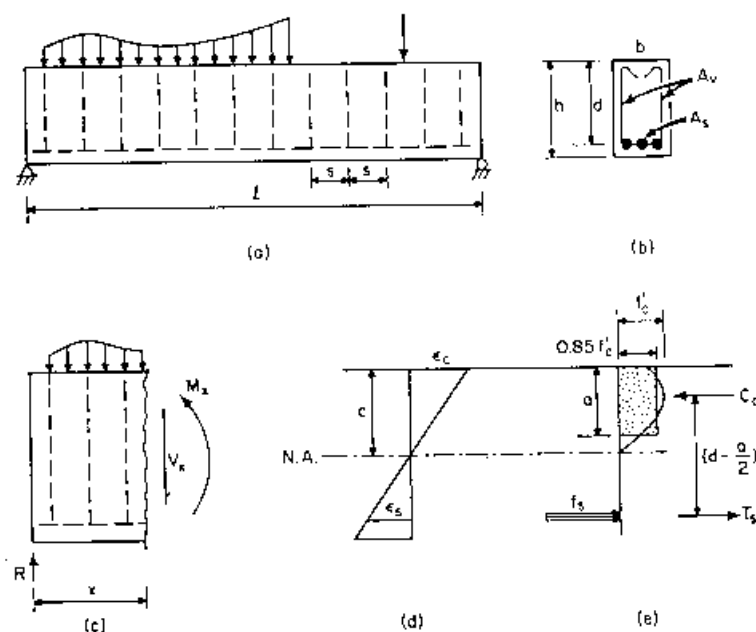

Fig. 1. A typical reinforced concrete beam: (a) profile; (b) cross section; (c) free body diagram; (d) strain variation; and (e) internal stresses and force resultants.

provided by the concrete. For simplicity, the parabolic stress distribution of concrete is replaced with an equivalent rectangular stress block which is shaded in Fig. 1(e). The concrete compressive force is, therefore, equal to:

$$C_c = 0.85 f'_c \times a \times b \quad (2)$$

Equilibrium of forces requires the above tensile and compressive forces to be equal. The external moment, M_x , must be resisted by the internal couple shown in Fig. 1(e), that is

$$M_x = T_s \times (d - a/2) \quad (3)$$

2 THE DECAYING INFRASTRUCTURE

The term infrastructure is defined as the basic facilities and installations needed for the economic growth and functioning of a nation. It includes a wide range of structures such as highways, railroads, airports, ports, bridges, power plants, dams, water and waste water treatment facilities, etc. In today's world, the competitiveness of any nation is directly related

to the welfare of its infrastructure. In most developed countries, the greater portion of the infrastructure was constructed several decades ago. Over the years, while new projects have been undertaken, little attention has been paid to the maintenance of the existing facilities. Consequently, many such structures are considered obsolete or inadequate to respond to the current demands.

Among the aging infrastructure, bridges are considered to have one of the worst records. In the USA, for example, about one-half of the approximately 600 000 bridges on the interstate system are in need of replacement or rehabilitation. Many of these bridges were originally designed for smaller vehicles, lighter loads and lower traffic volumes than are common today.³ As a result, a large number of these bridges have inadequate load-carrying capacity for today's traffic. Maintenance alone will not bring these bridges up to current standards. Strengthening must also be considered. It is the latter which forms the main focus of this paper.

3 STRENGTHENING METHODS

The flexural strength of a concrete beam is given by eqn (3). Most building and bridge codes require that the failure of the beam be controlled by the failure (i.e. yielding) of the tension steel.^{4,5} In other words, in a beam such as the one shown in Fig. 1, the ultimate strength will be reached when the steel rebars yield. Therefore, if additional tension reinforcement were added to the beam, the ultimate strength will increase accordingly. The addition of tension reinforcement is desirable in two cases. First, in beams where corrosion has gradually reduced the area of the original tension steel and thereby reduced the load-carrying capacity of the member. Second, where additional reinforcement is needed to increase the strength of the beam beyond its original strength so that it can accommodate heavier traffic.

In selecting an appropriate repair technique, care must be taken so that disturbance to the flow of traffic is minimized during the repair. Among the methods used to strengthen beams in existing bridges are external post-tensioning and the addition of epoxy-bonded steel plates to the tension flange. The latter is easier to perform in many cases and forms the basis for the method presented here.

The addition of epoxy-bonded steel plates to the tension face of concrete girders has been used effectively in Europe, South Africa, and Japan.³ In the first reported application, the accidental omission of tension steel in concrete beams of an apartment complex in Durban,

South Africa, was discovered after the construction was completed.⁶ The beams were strengthened with steel plates bonded to their tension flange. In the UK, four bridges on the M5 motorway at Quinton Interchange, Worcestershire and two bridges on the M25-M20 motorway interchange at Swanley, Kent were strengthened by plating.⁶ Other examples include a reinforced concrete-through-arch bridge in Switzerland,³ a skewed T-beam bridge in France⁷ and several reinforced and prestressed concrete bridges in Poland.³

When steel plates are epoxied or bolted to the tension face of a beam, in addition to the tension force, T_s , described previously in Fig. 1(d), a tension force, T_p , will be developed in the plate which is located at the bottom of the beam. The magnitude of this force is given by:

$$T_p = A_p \times f_p \quad (4)$$

where A_p and f_p are the cross-sectional area and tensile stress in the plate, respectively. The concrete compressive force will increase and become equal to the sum of the tensile forces in the steel reinforcement and the plate. The larger tensile and compressive forces result in a significant increase in the internal resisting moment and consequently in the flexural strength of the beam.

A major shortcoming of this system, however, is the deterioration of the bond between the plate and the beam caused by the corrosion of steel. Moreover, the exposed steel plate will require significant maintenance and protection against corrosion. An effective method to eliminate the corrosion problem is to replace the steel plate with a corrosion-resistant material such as Glass-Fiber-Reinforced-Plastic (GFRP) plate.

4 OBJECTIVE AND SCOPE

The main objective of this study is to determine the feasibility of strengthening concrete beams by epoxy-bonding GFRP plates to the tension face of beams. Efforts were made to limit the selection of the plates and epoxies to those which are commercially available at fairly low costs. Once the feasibility of this strengthening technique has been established, studies can be undertaken to select more suitable materials for this application.

5 TEST PROGRAM

The experimental program consisted of two parts. Due to the significant effect of adhesives on the performance of the strengthened beams, in the

first part of the study, four small-scale beams were tested to evaluate several epoxies and select the most promising one. In the second phase, the behavior of a large-scale beam strengthened with the proposed method was studied.

The overall dimensions of the specimens are shown in Fig. 2 and their details are listed in Table 1. The beams were simply supported and subjected to two equal and concentrated loads, symmetrically placed about the mid-span. The load was incrementally applied at a constant rate up to failure of each beam. The mid-span deflections for the beams were measured using dial gages. The GFRP plates used in this study had a 70% glass (Type E) content by weight. The ultimate strength of the plate was 380 MPa with a modulus of elasticity of 37 200 MPa (about one-quarter that of steel).

5.1 Small-scale beams

The success of the proposed strengthening technique depends greatly on the type of epoxy employed. Many studies have been conducted on the performance of epoxies for use in steel structures.^{8,9} In concrete beams, tensile stresses cause cracking of the extreme fiber of the concrete. Therefore, the epoxy must be capable of dissipating the energy released from this cracking and strong enough to resist the large shear stresses present. Because no such data were available, the performance of three promising epoxies was evaluated by means of testing four small-scale rectangular concrete beams.

The dimensions of the specimens are listed in Table 1. The tension face of three of the beams was sand-blasted clear to the aggregate before the GFRP plates were attached to them. A different epoxy was used for each of the three beams. Accordingly, these beams are referred to as beams A, B, and C depending on the type of epoxy used. The fourth

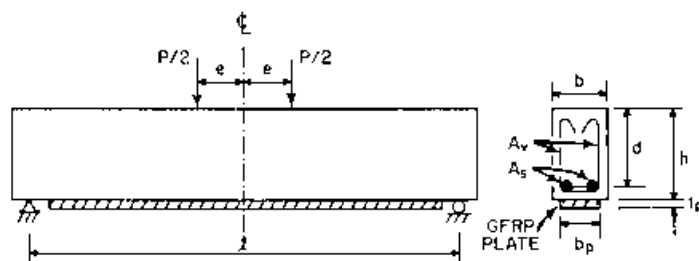

Fig. 2. General view of the test specimens.

TABLE I
Physical Dimensions of the Test Specimens

	<i>Small beams</i>	<i>Large beams</i>
b (mm)	90	200
h (mm)	150	460
d (mm)	130	405
h_p (mm)	75	150
r_p (mm)	6	6
l (m)	1.52	4.57
c (mm)	75	305
A_s (mm ²)	70	260
A_p (mm ²)	20	260
s (mm)	75	150

beam was not strengthened and was used as a control specimen. The average compressive strength of concrete was 36.4 MPa. The measured yield strengths for the longitudinal and shear steel reinforcement were 555 MPa and 589 MPa, respectively.

In Fig. 3, the load versus deflection responses of beams A, B, and C are compared with that of the control beam. The epoxy used for beam A was fairly flexible. The uncured epoxy had a relatively low viscosity and could easily flow under a slight pressure. The cured epoxy was black and had a rubbery texture. The required curing time was 24 hours at 25°C. As Fig. 3 indicates, the initial stiffness of beam A was slightly higher than that of the control specimen. The stiffness of both beams reduced after the concrete cracked at a load of approximately 7 kN. The load-deflection response continued almost linearly until the longitudinal steel yielded. At that point, due to large tension cracks, the bond between the plate and the beam failed gradually in a ductile manner and the GFRP plate separated completely from the beam. The failure was in the adhesive without any damage to either the concrete or plate surfaces. Consequently, the control beam and beam A had virtually the same failure load. It was concluded that because this particular epoxy was too flexible, no measurable shear could be transferred between the plate and the beam and therefore, no increase in the ultimate capacity could be achieved.

The epoxy used for beam B was the least viscous of the three epoxies and had a consistency similar to that of oil. The two components were available in spray cans and were applied sequentially to the surfaces of the beam and the plate. The epoxy was cured at room temperature for 24 hours. The cured epoxy was stiffer than the epoxy used for beam A.

Figure 3 indicates a substantial increase in the stiffness of the strengthened beam compared with beam A. At a load of approximately 36 kN, large shear cracks were observed in the beam and failure was imminent. The premature shear failure is attributed to the flexural strengthening of the beam without shear strengthening. At this point, the beam was completely unloaded and the regions of shear distress were strengthened by means of external clamps. The beam was then reloaded and the loading continued until the beam failed at a load of 31 kN. The failure was caused by the separation of the plate and the beam, particularly around the base of the shear cracks where the concrete to plate bond had been severely damaged in the first cycle of loading.

The two-part epoxy used for beam C was relatively viscous and had a consistency similar to that of cement paste. The pot life of approximately half an hour was found to be adequate for applying the epoxy to both surfaces. The cured epoxy was substantially stiffer than the epoxies used for beams A and B. In order to prevent a premature shear failure similar to the one observed in beam B, external shear reinforcement was provided in the end regions of the beam. The required curing time for this epoxy was 4 hours. As seen in Fig. 3, the stiffness of this beam increased significantly compared to the control specimen. The beam was loaded to failure without any shear distress. It reached an ultimate load more than twice that of the control specimen. Additionally, no significant tension cracks were observed up to a load of approximately 44 kN. Beyond that load, the cracks were very fine and well distributed along the beam. The failure was reached by delamination of a layer of concrete about 7 mm away from the bond line along the full beam length, indicating satisfactory performance of the epoxy. Figure 4 shows the beam and the plate placed on a table at the conclusion of the test.

Based on the above tests, it was decided to use the same epoxy as that in beam C for the test of the large-scale beam.

5.2 Large-scale beam

The results from the small-scale tests indicated the effectiveness of this technique for strengthening existing girders. In order to observe the behavior of full-scale beams, a larger specimen was also constructed and tested. Design details of this specimen are given in Table 1. Additional large-scale tests will be performed in the near future to examine the effect of various parameters on the behavior of strengthened beams.

In a typical reinforced concrete structure such as a bridge, the self-weight of the structure causes deflection of the beam and introduces microcracks in the concrete on the tension face (i.e. bottom) of the beam.

These cracks reduce the stiffness of the structure and allow penetration of moisture which will lead to corrosion of the reinforcing steel. The strengthening method used for the small-scale beams can be slightly modified to correct these two problems.

If desired, the beam, in loose contact with the epoxy-coated plate, can be jacked upward and held in that position until the epoxy is cured.

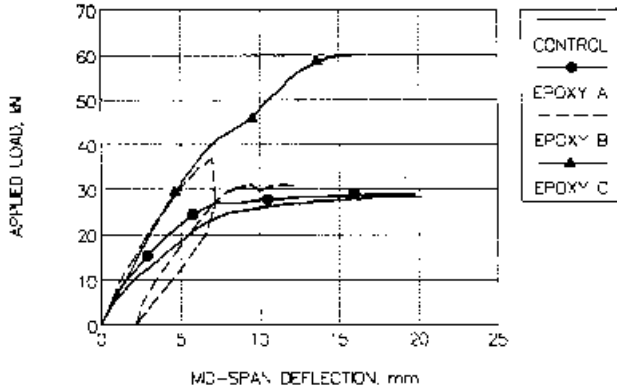

Fig. 3. Load versus mid-span deflection for the small-scale beams.

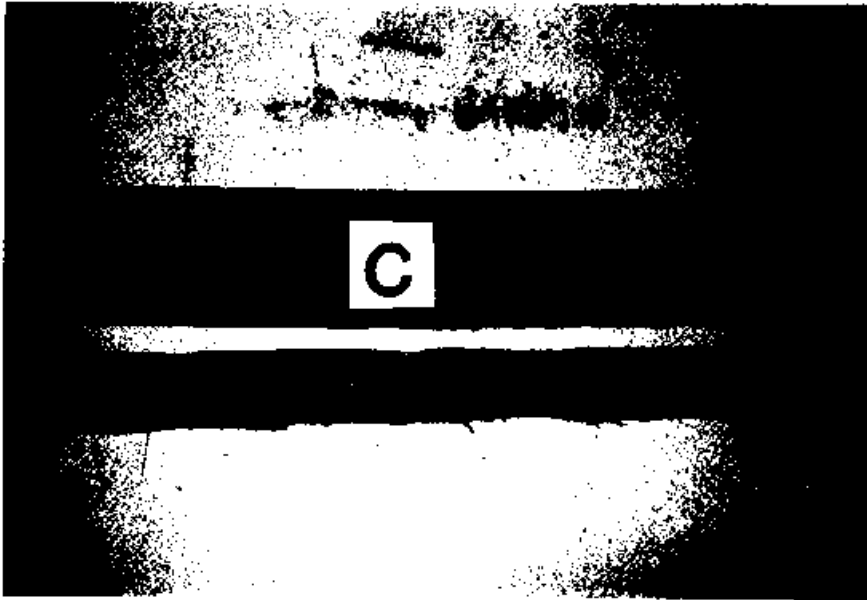

Fig. 4. Beam C at the conclusion of the test.

Upon removing the jacks, the plate will prevent the beam from returning to its original deflected shape. This action, known as external prestressing, introduces compressive stresses in the bottom of the beam which will delay tension cracking of the beam and consequently increase the stiffness of the structure.

The large-scale beam reported here was strengthened in this manner. Design details for this specimen are presented in Table 1. Because the external prestressing operation introduces initial tensile stresses in the top of the beam, reinforcing bars must be placed near the top to prevent premature failure of the beam. Although not shown in Fig. 2, this beam was constructed with two steel bars each having an area of 130 mm^2 placed at 55 mm from the top of the beam. Such reinforcement is always present in a structure such as a bridge and will rarely become a limiting factor for this technique. After the surface of the beam was sand-blasted and cleaned, the beam was cambered and the GFRP plate was bonded using the same epoxy as that of beam C from the small-scale tests.

As shown in Fig. 5, the external prestressing resulted in a negative (i.e. upward) deflection of 5 mm in the beam before it was loaded. Because the area of tension reinforcement for this beam was relatively low, the beam without the GFRP plate would have failed at a load of 44 kN only. The stiffness of the strengthened beam reduced after the tension face cracked at a load of approximately 18 kN. The post-cracking response of the beam was almost linear with small cracks distributed along the entire length of the beam. The beam failed at a load of 186 kN, which is more than four times the predicted failure load of the beam without the plate. This clearly points to the potential of this technique as a method for rehabilitation and strengthening of structures.

The beam failed as a result of shear failure of concrete in a plane parallel to and about 40 mm above the tension face. The failure was rather violent; concrete near the region of constant moment of the beam tore apart with the plate. Figure 6 shows the beam and the separated GFRP plate at the end of the test. Additional large-scale beams will be tested in the future to examine the effect of various parameters on the behavior of the strengthened beam.

6 ADDITIONAL STUDIES

Composite materials offer unique properties for many structural engineering applications. One such study currently in progress at the University of Arizona is the strengthening of columns. In conjunction with strengthening of girders in a bridge, the piers may require

strengthening too. In addition, many older bridge piers located in seismic zones, may require retrofitting to supplement the insufficient ties used in the original design.

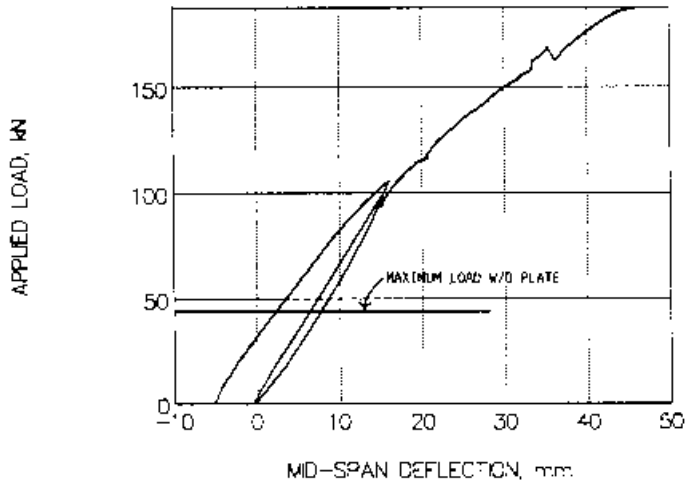

Fig. 5. Load versus mid-span deflection for the large-scale beam.



Fig. 6. Large-scale beam at the conclusion of the test.

An effective and economical method used to increase the ductility and shear resistance of concrete columns in existing bridges is to externally confine and/or laterally prestress the columns with composite straps. The straps are constructed from high-strength and flexible fibers weaved to form a fabric-like material of desired width and length. Materials such as Kevlar or graphite are excellent candidates for this application. Kevlar fibers, for example, are extremely strong in tension and can reach an ultimate strength of well above 3000 MPa. The reinforcement is performed by wrapping straps of desired widths around the columns. The straps can be wrapped in a continuous spiral and/or discontinuous rings. The fabrics can be made very thin, i.e. less than 2 mm thick. This results in sufficient flexibility for the straps to be wrapped around circular as well as rectangular columns.

Additional advantages can be gained at the time of strengthening by laterally prestressing the columns. The prestressing can be accomplished by wrapping the straps around the column while under tension. The lateral confining pressure produced in such a manner will increase the compressive load carrying capacity of the concrete considerably. In the event of severe seismic loading, for example, such confinement will prevent the shell region of the column from spalling. This will prevent buckling of the longitudinal bars and will make the entire concrete section effective in resisting the loads. A pilot study on this application is currently underway where the gain in strength and ductility of concrete cylinders is being investigated.

7 SUMMARY AND CONCLUSIONS

The preliminary results from tests of small- and large-scale reinforced concrete beams strengthened with Glass-Fiber-Reinforced-Plastic (GFRP) plates are presented. The results indicate great potential for the use of the proposed strengthening technique in civil engineering structures. Among the advantages of the method are its low cost and ease of application. The success of the method depends to a great extent on the type of epoxy employed. Of the three epoxies examined, one was found to perform adequately for the static tests conducted.

Although the stiffness of the plate used was fairly low, the stiffness of the strengthened beams was significantly increased. This was attributed to a reduction in the width of the concrete tension cracks at the presence of plate. In addition, the presence of the plates increased the load corresponding to first cracking of the beam to more than twice that of the control beam. The gain in strength is a function of the cross-sectional

area and the area of steel reinforcement in the unrepaired specimen. In one of the specimens reported, the strength of the beam was increased to more than four times that prior to the repair. Before field applications of this method are made, however, additional studies are needed to address several points of concern. Among these are the fatigue strength of the system under repeated loading, increasing the shear strength of the beams using a similar technique, and long-term behavior of the entire system, including the effects of creep of the epoxy and plate under sustained loads. The solution to these problems requires close collaboration between structural engineers and material scientists.

REFERENCES

1. MacGregor, J. G., *Reinforced Concrete Mechanics and Design*. Prentice Hall, New Jersey, 1988, 799 pp.
2. Ferguson, P. M., Breen, J. E. & Jirsa, J. O., *Reinforced Concrete Fundamentals*. John Wiley & Sons, New York, 1988, 746 pp.
3. Klaiber, F. W., Dunker, K. F., Wipf, T. J. & Sanders, W. W., Methods of strengthening existing highway bridges. National Cooperative Highway Research Program, Report No. 293, September 1987, 114 pp.
4. American Association of State Highway and Transportation Officials, Standard specifications for highway bridges. AASHTO, 1983, 394 pp.
5. ACI Committee 318. Building code requirements for reinforced concrete (ACI 318-83). American Concrete Institute, Detroit, Michigan, 1983, 111 pp.
6. Dussek, I. J., Strengthening of bridge beams and similar structures by means of epoxy-resin-bonded external reinforcement. Transportation Research Record 785, Transportation Research Board, 1980, pp. 21-4.
7. Bresson, J., Strengthening by bonded reinforcing of the underpass on CD 126 on the southern autoroute. *Annales Publices*, France, 297 (September 1972) 2-24.
8. Albrecht, P., Mecklenburg, M. F., Wang, J. & Hong, W. S., Effect of environment on mechanical properties of adhesives. Report No. FHWA/RD-87/029, Federal Highway Administration, February 1987, 167 pp.
9. Albrecht, P., Sahli, A. H., Crute, D., Albrecht, P. H. & Evans, B. M., Application of adhesives to steel bridges. Report No. FHWA/RD-84/037, Federal Highway Administration, November 1984.